

Q20

Counterbalanced Forklift

Bridge the last "100 meters" of smart intralogistics transportation

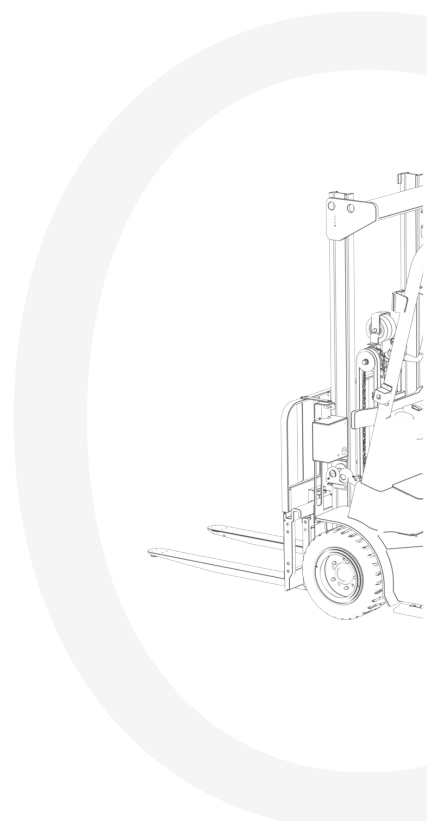

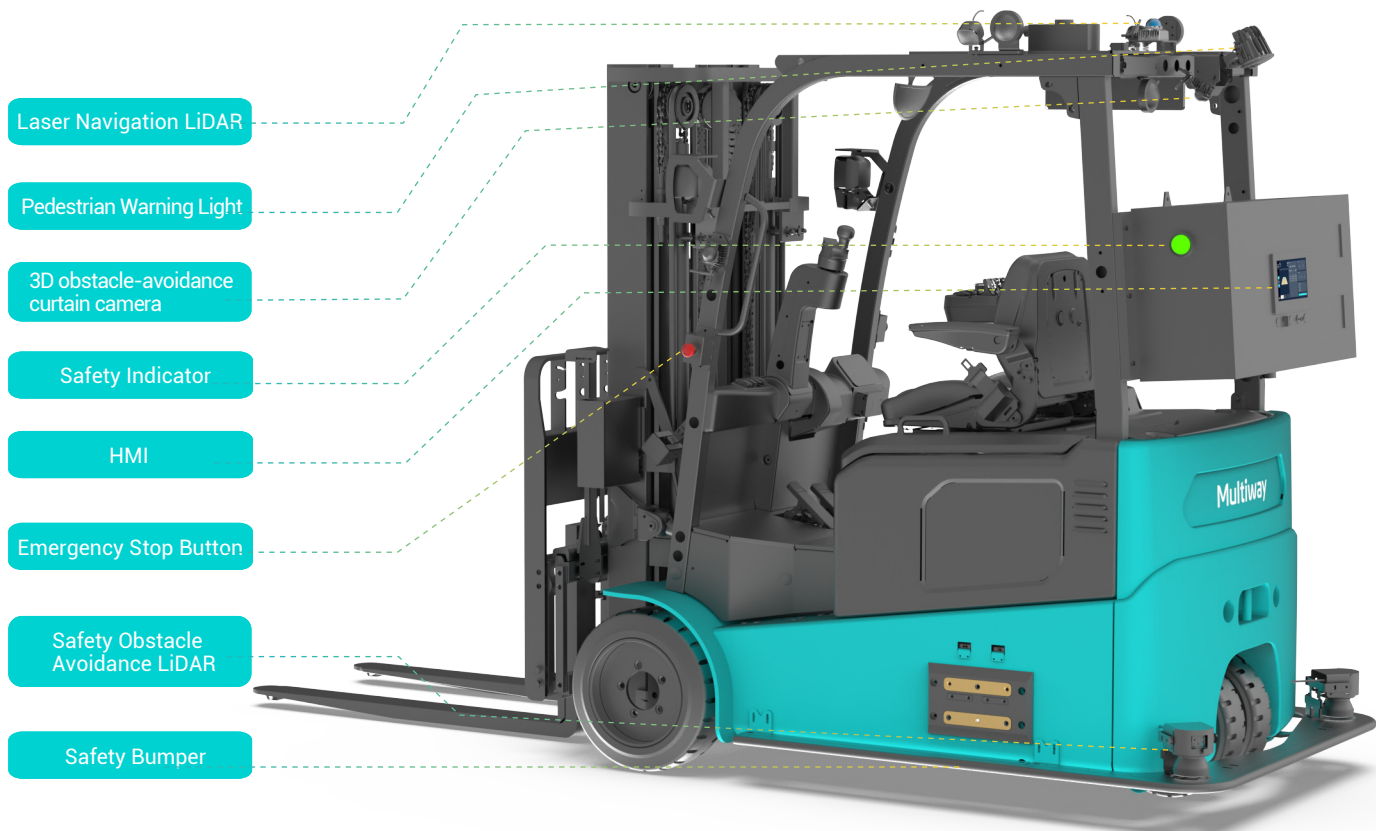

Introduction

Bridging the last "100 meters" of intelligent intralogistics transportation, the Q20 counterbalanced AGV forklift, a customized machine for automated loading and unloading, is compatible with various types of pallets such as Open Pallet, Closed Pallet, and POD pallets. It has a maximum load capacity of 1550kg, a lifting height of 1500mm, and the forks support horizontal movement and pitch motion. It is suitable for various scenarios such as floor-to-floor handling, heavy-load stacking, and automated loading and unloading of different trucks (Wing type, flatbed, trailer etc.). It is an ideal choice for automation and digital upgrades in warehousing logistics, production intralogistics, loading and unloading logistics.

Features



Environment Adaptive

With laser navigation and positioning, there's no need to renovate the on-site environment.



Highly Intelligent

A whole range of functions such as mapping, path planning, auto-charging, and intelligent operations for various scenarios.



Non-stop Pallet Pose Identification

Visual perception non-stop pallet pose identification can realize fast and accurate pick-and-place of goods.



Intelligent Safety

Comprehensive fault self-detection
360° obstacle avoidance and sound & light warning.

Autonomous Loading & Unloading Scenarios

Wing Type Truck Loading and Unloading Solutions

Based on the structural characteristics of the open compartment of the wing type truck, using unmanned forklift trucks to load and unload.

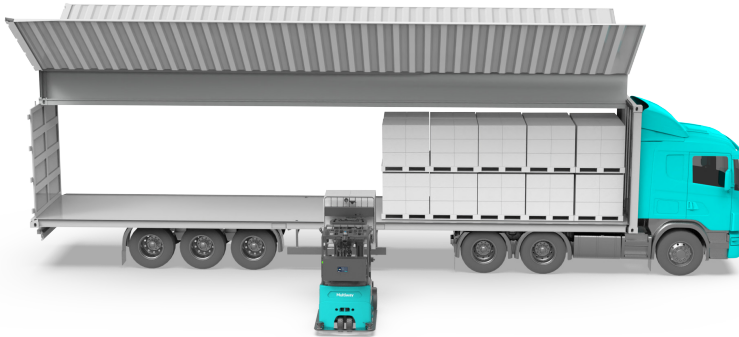

Support different height of wing type truck



Support mixed (un)loading

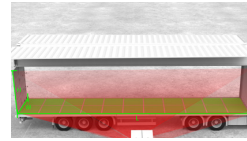

Dimensions measurement and space allocation



Maximum space utilization with 0 clearance

Flatbed Truck Loading and Unloading Solutions

Automated loading and unloading of flatbed trucks using unmanned forklifts as the carrier for top-open vehicles such as flatbed and high-bay trucks.



Support different height of flatbed truck



Support mixed (un)loading



Dimensions measurement and space allocation



Maximum space utilization with 0 clearance

Trailer Truck Loading and Unloading Solutions

With unmanned forklift truck as the carrier, the innovative 3D lidar simultaneous localization and mapping (SLAM) and flexible vision technology are used to automate the trailer loading and unloading, suitable for pallet or pallet-free situation, as well as stacking goods in the truck.



Max deck slope at 8.5°

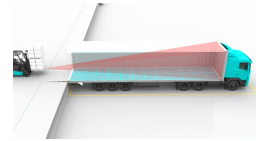

Dimensions measurement and space allocation



Access to last set of cargos



Maximum space utilization with 0 clearance

Q20 Counterbalanced Forklift

Specifications

	Model	Q20
Basic Parameter	Navigation	LiDAR Navigation(3D SLAM) / Mixed Navigation
	Communication	Wi-Fi / 5G / Optical Communication
	Driving Features	Forward, Reverse, and Turn
	Control Mode	Auto/Manual
	Rated Load (kg)	1550
	Load Center (mm)	500
	Weight (Including battery) (kg)	3700
	Turning Radius (mm)	1828
	Aisle Width (mm)	4100
	Maximum Lifting Height (mm)	1500
	Dimensions L×W×H (mm)	3398x1244x2266
	Fork Dimensions L×W×H (mm)	1070x100x40
	Fork Outer Space (mm)	350~920
Minimum Height of Fork From the Ground (mm)	50±5	
Movement Specifications	Positioning precision/ Stop Angle (Center of bearing wheel) (mm/ °)	±20/±1°
	Obstacle Clearing Capability	≤30
	Climbing Capacity	Full Load≤8.5° (15%) /No Load≤8.5° (15%)
	Cross-Groove Capability (mm)	≤30
	Max Driving Speed (No Load/Full Load) (m/s)	2.5/2
	Max Lifting Speed (No Load/Full Load) (mm/s)	550/360
	Max Descent Speed (No Load/Full Load) (mm/s)	550/500
Battery Specifications	Battery Voltage/Capacity (V/Ah)	48V450Ah
	Charging Mode	Auto/Manual
	Run time	8~10h
	Battery Life	Complete charge-discharge 2500 times ≥70%
Functions of the Forks	Goods Detection	Standard
	Inclination Detection (Pitch)	Standard
	Side/Traverse Positioning	±200mm
	Automatic Fork Distance Adjustment	Optional
	Overload Alarm (±5%)	Optional

Note: In the real-time update of product parameters, the above parameters are for reference only and shall prevail.

Attachment



Pitch



Traverse



Automatic distance adjustment



Overweight alarm

Customize



Explosion-proof



Cold chain

Carrier

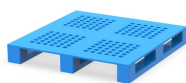

2-way pallet

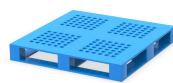

4-way pallet



Cage



Cart

Comprehensive safety protection:

Sound perception + obstacle avoidance + touch reception, 360° omnidirectional three-layer protection

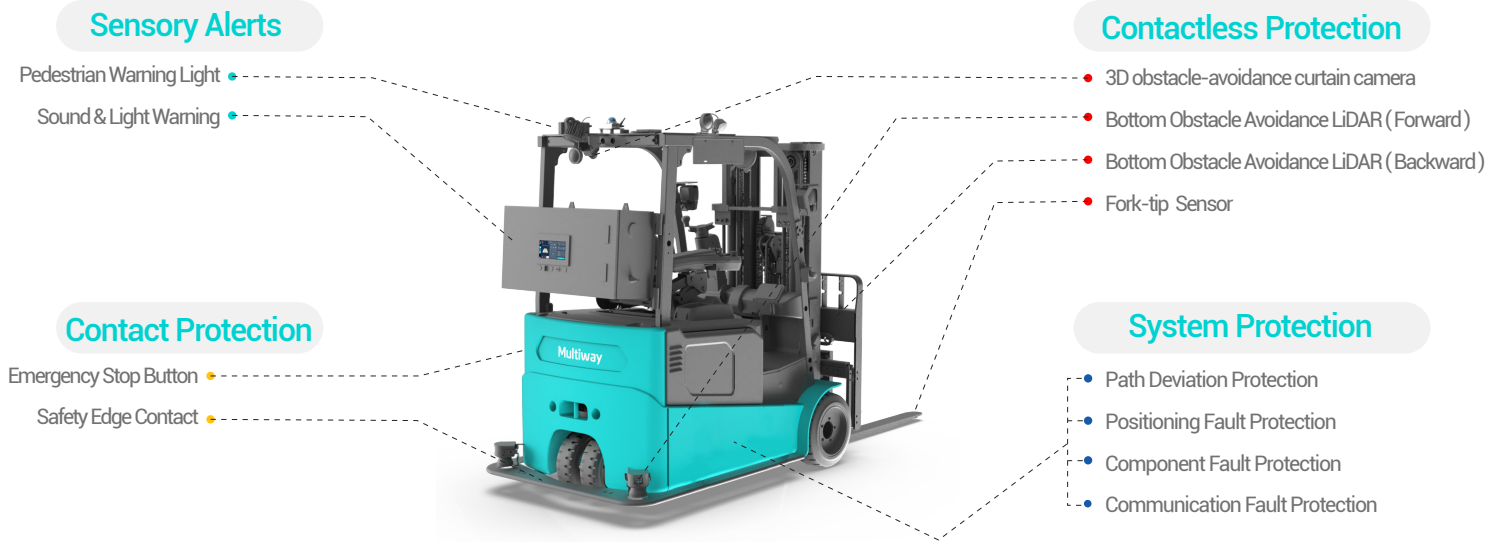

Point Cloud Obstacle Avoidance:

The forward simulation algorithm can measure the distance to obstacles, autonomously plan the moving speed, ensure the vehicle accelerates and decelerates smoothly without sudden changes in speed.

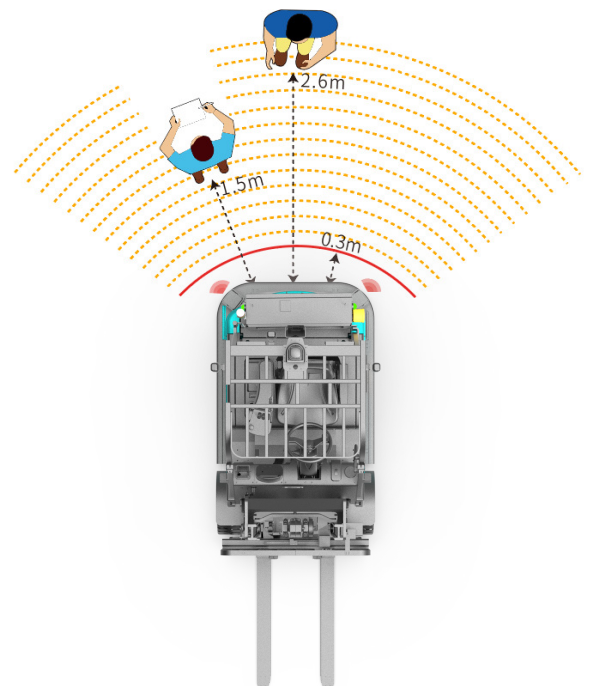
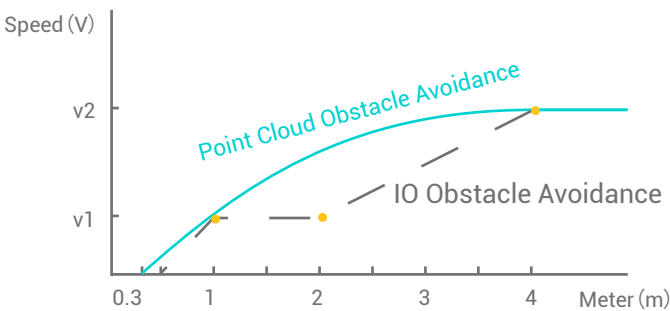

Multiway Robotics

Multiway Robotics is committed to "Empowering the World with Billions of Robots" and takes "To create a new and efficient operating mode" as its mission, continuously driving the advancement of global productivity.

Global Presence: The headquarters is located in Shenzhen, China, with production facilities in Zhejiang Wuzhen. Multiway has also established subsidiaries in the United States, Germany, Japan, South Korea, and more, extending business, operations, and services to 40+ countries and regions worldwide.

Our Expertise: Focusing on advanced robotics and AI technology, Multiway Robotics is committed to delivering cutting-edge Smart Intralogistics Solution to our customers. Multiway offers a comprehensive, integrated innovation delivery platform and solutions, ranging from core sensors and algorithms to self-developed unmanned forklifts and upper-level control systems. Hardware products include a full range of unmanned forklifts and four-way shuttle, while software systems encompass WMS, RCS, WCS, on-site management systems, and various visual solutions.

Software: WMS, RCS, WCS, Multiway Horizons, Simulation

Hardware: AGV forklifts, AGV Tugger, AMR & Four-way Shuttle

After successfully delivering numerous benchmark projects in industries such as factories, warehousing, and logistics, Multiway has become a trusted and ongoing collaborative partner for many industry-leading customers.



Contact Us

Offices:

USA · Atlanta | Japan · Tokyo | Korea · Seoul
Germany · North Rhine-Westphalia
China · Shenzhen

Hotline: + 86 133 9286 4873

Official website: www.mw-r.com

Email: sales@mw-robot.com

Subscribe to get the latest Multiway Robotics news