

K Series

VNA Truck

K16

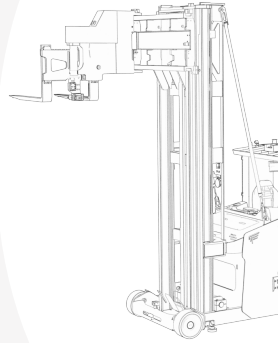

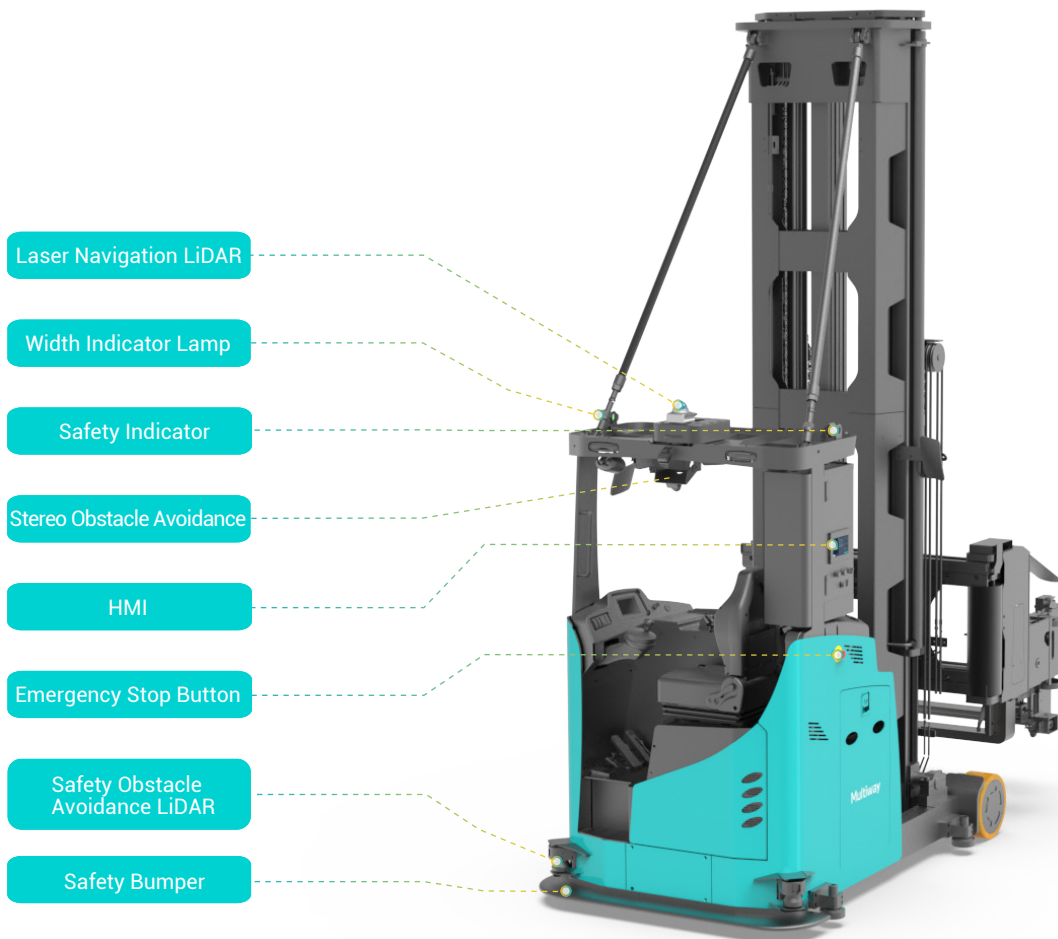

Introduction

The VNA truck MW-K16 applied to the high-bay storage of a narrow passageway, with payload of 1500 kg and max lifting height of 16500 mm. The cargo stacking and loading/ unloading on both sides of the passageway can be realized through 180° rotation of the fork and left/ right side movement without turning the body.

Features



Environment Adaptive

With laser navigation and positioning, there's no need to renovate the on-site environment.



Highly Intelligent

A whole range of functions such as mapping, path planning, auto-charging, and intelligent operations for various scenarios.



Dense Storage

The narrowest roadway is only 1.75 meters



Intelligent Safety

Comprehensive fault self-detection
360° obstacle avoidance and sound & light warning.

Narrow roadway high bay storage

The VNA truck narrow roadway high bay storage solution has high cargo access efficiency. The fork arm of the vehicle adopts a three-way fork design, which improves space utilization and reduce warehouse construction costs.

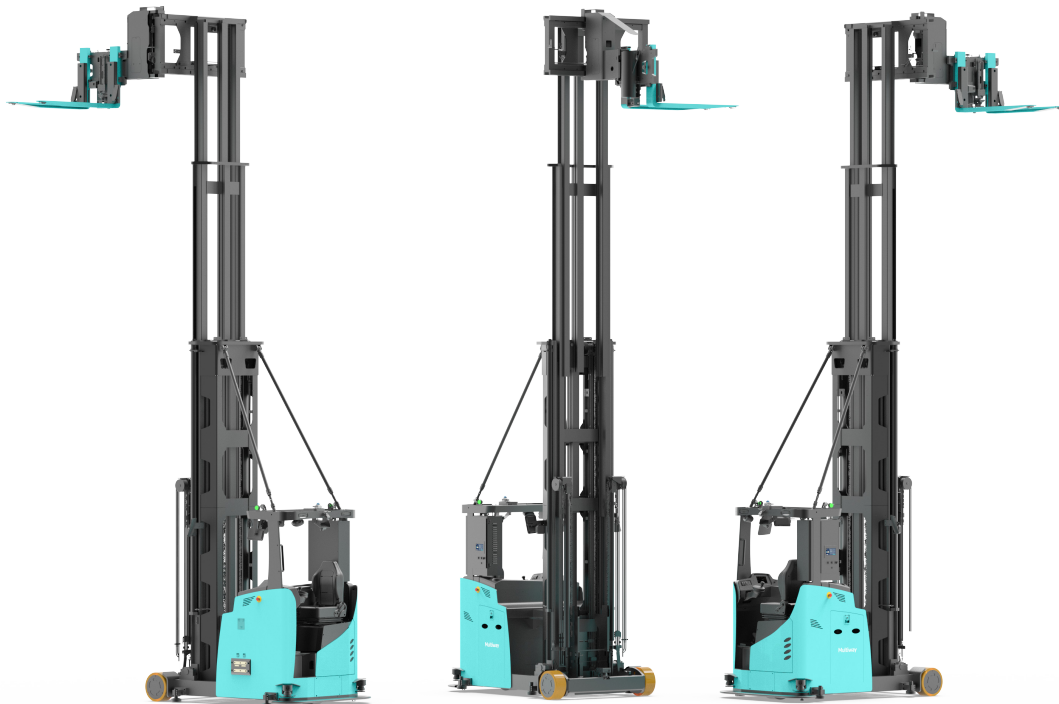

K Series K16 VNA Truck

Specifications

	Model	K16
Basic Parameter	Navigation	LiDAR Navigation / Mixed Navigation
	Communication	Wi-Fi / 5G / Optical Communication
	Driving Features	Forward, Reverse, and Turn
	Control Mode	Auto/Manual
	Rated Load Q (kg)	1500
	Load Center C (mm)	500
	Weight (Including battery) (kg)	6280~7260
	Turning Radius Wa (mm)	2250
	Aisle Width (mm)	1750
	Maximum Lifting Height (mm)	16500
	Dimensions L×W×H (mm)	3456×1625× (2935~4265)
	Fork Dimensions l×e×s (mm)	1200×125×50
	Fork Rack Width b2 (mm)	820
Fork Outer Space b3 (mm)	265~760	
Minimum Height of Fork From the Ground h6 (mm)	60±5	
Movement Specifications	Positioning precision/ Stop Angle (Center of bearing wheel) (mm/ °)	±10/±1
	Obstacle Clearing Capability	≤10
	Climbing Capacity	≤2° (3%)
	Cross-Groove Capability (mm)	≤30
	Max Driving Speed (No Load/Full Load) (m/s)	2.2/1
	Max Lifting Speed (No Load/Full Load) (mm/s)	300/300
Max Descent Speed (No Load/Full Load) (mm/s)	300/300	
Battery Specifications	Battery Type	Lithium Iron Phosphate
	Battery Voltage/Capacity (V/Ah)	48V/450AH
	Charging Mode	Auto/Manual
	Run time	6~8h
	Battery Life	Complete charge-discharge 2500 times ≥70%

Note: In the real-time update of product parameters, the above parameters are for reference only and shall prevail.

Attachment

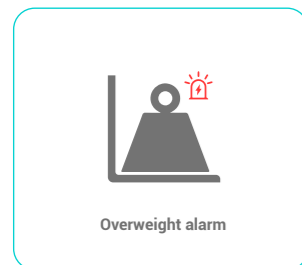

Customize



Carrier

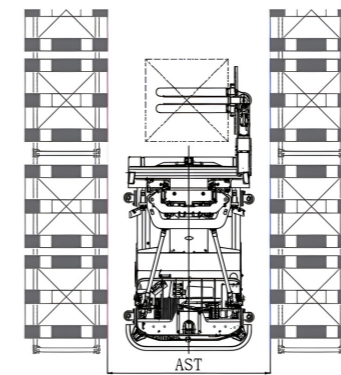
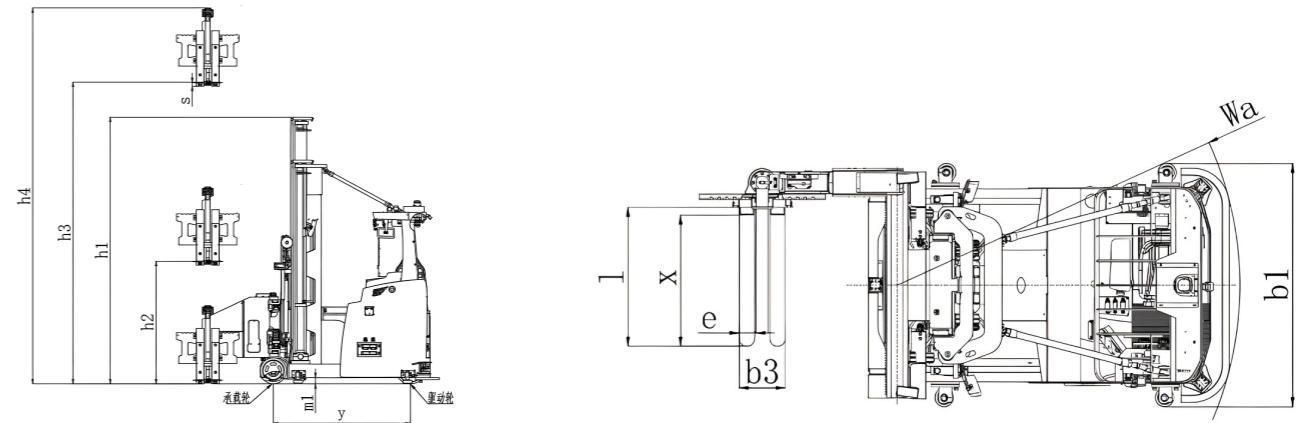
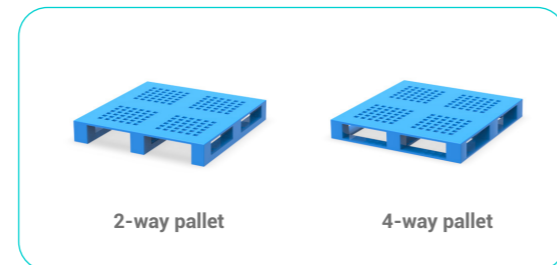

Aisle width & Turning radius			
Pallet (mm)	1000 ↑ x1000	1000 ↑ x1200	1200 ↑ x1200
AST (mm)	1750		
Spin diameter (mm)	4300		

Mast Specification

Triplex Mast												
Lifting height	h3 (mm)	4500	5000	5500	6000	6500	7000	7500	8000	8500	9000	9500
Mast closure height	h1 (mm)	2765	2935	3100	3265	3435	3600	3765	3935	4100	4265	4435
Mast height when lifting	h4 (mm)	5650	6150	6650	7150	7650	8450	8650	9150	9650	10150	10650
Free lifting height	h2 (mm)	1670	1830	2000	2170	2330	2500	2670	2830	3000	3170	3330

Load curve

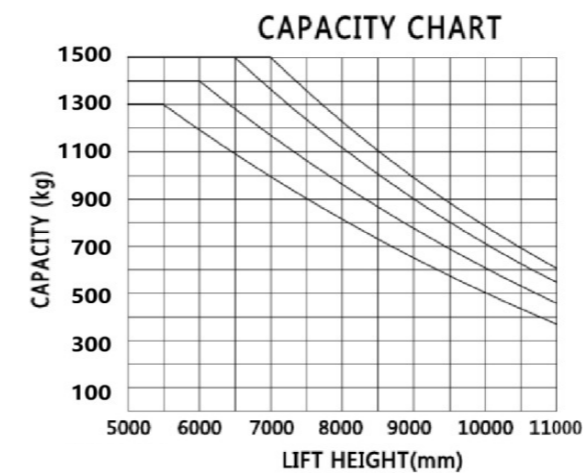

Comprehensive safety protection:

Sound perception + obstacle avoidance + touch reception, 360° omnidirectional three-layer protection

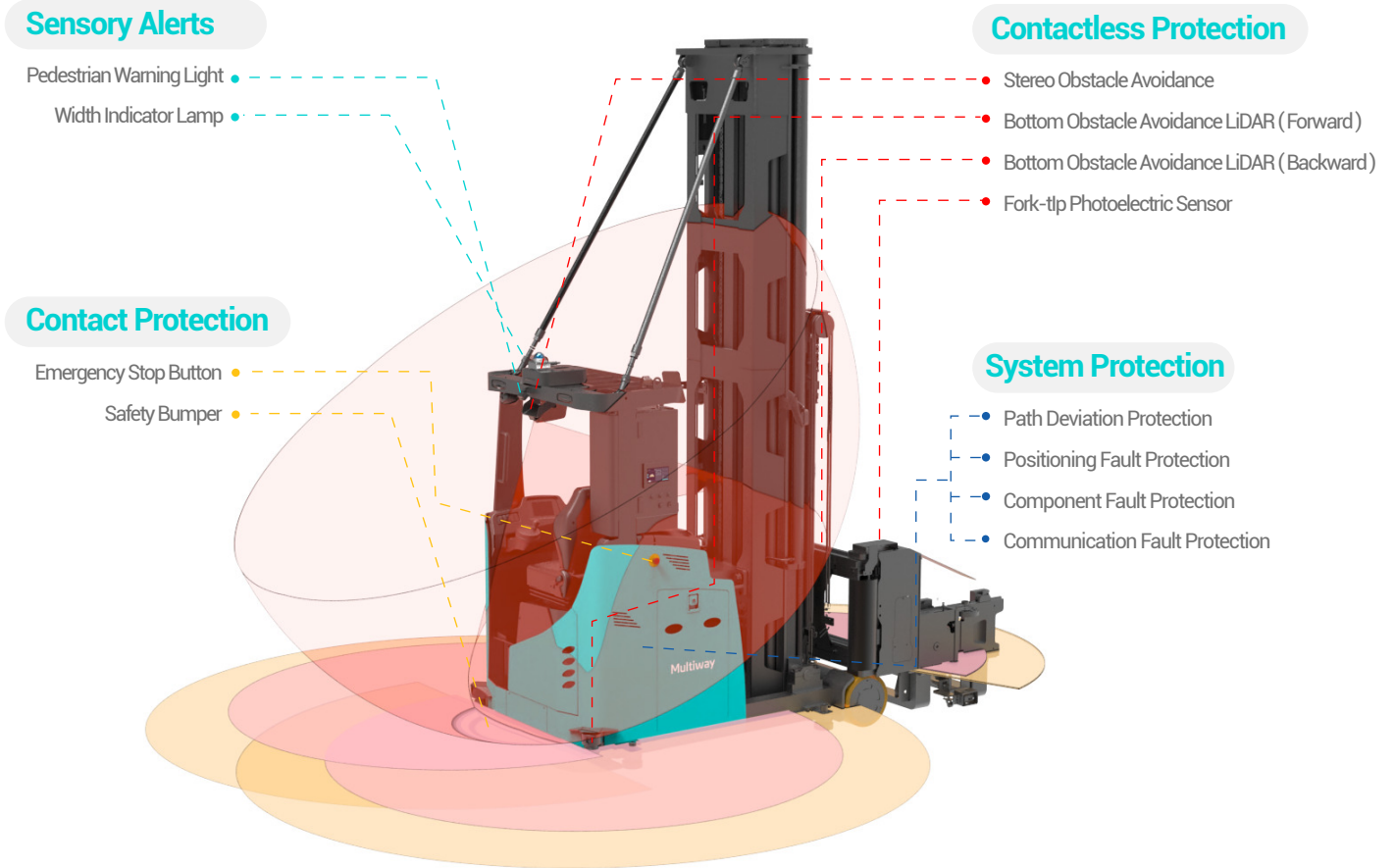

Point Cloud Obstacle Avoidance:

The forward simulation algorithm can measure the distance to obstacles, autonomously plan the moving speed, ensure the vehicle accelerates and decelerates smoothly without sudden changes in speed.

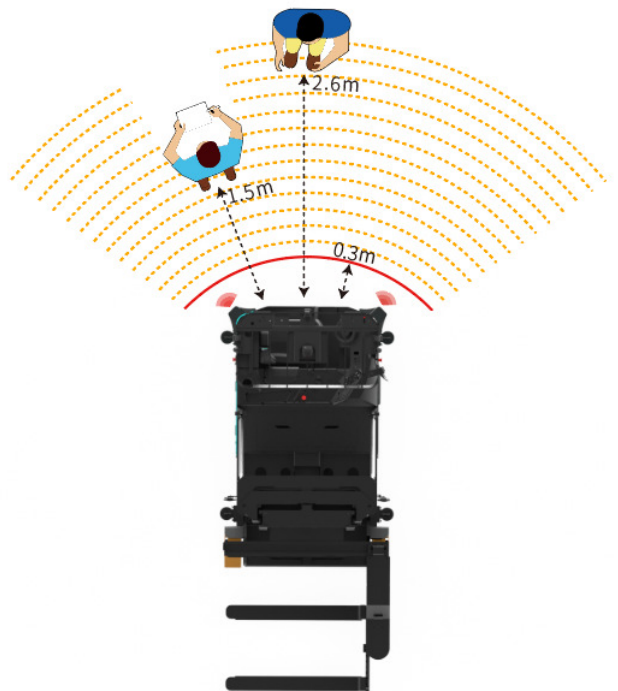
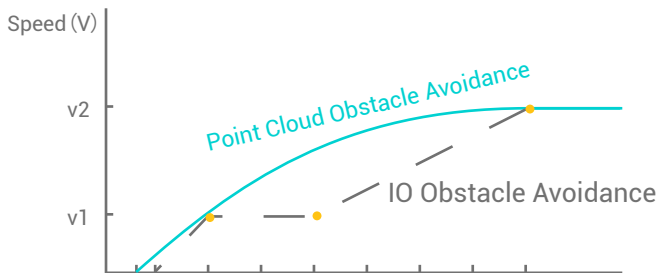

Multiway Robotics

Multiway Robotics is committed to "Empowering the World with Billions of Robots" and takes "To create a new and efficient operating mode" as its mission, continuously driving the advancement of global productivity.

Global Presence: The headquarters is located in Shenzhen, China, with production facilities in Zhejiang Wuzhen. Multiway has also established subsidiaries in the United States, Germany, Japan, South Korea, and more, extending business, operations, and services to 40+ countries and regions worldwide.

Our Expertise: Focusing on advanced robotics and AI technology, Multiway Robotics is committed to delivering cutting-edge Smart Intralogistics Solution to our customers. Multiway offers a comprehensive, integrated innovation delivery platform and solutions, ranging from core sensors and algorithms to self-developed unmanned forklifts and upper-level control systems. Hardware products include a full range of unmanned forklifts and four-way shuttle, while software systems encompass WMS, RCS, WCS, on-site management systems, and various visual solutions.

Software: WMS, RCS, WCS, Multiway Horizons, Simulation
Hardware: AGV forklifts, AGV Tugger, AMR & Four-way Shuttle

After successfully delivering numerous benchmark projects in industries such as factories, warehousing, and logistics, Multiway has become a trusted and ongoing collaborative partner for many industry-leading customers.



Contact Us

Offices:

USA · Atlanta | Japan · Tokyo | Korea · Seoul
Germany · North Rhine-Westphalia
China · Shenzhen

Hotline: + 86 133 9286 4873

Official website: www.mw-r.com

Email: sales@mw-robot.com

Subscribe to get the latest Multiway Robotics news

